



# VARVEL®

MOTION CONTROL SINCE 1955

technology made in Italy



IT  
EN  
DE

 **VARfarm**  
by VARVEL



## Tecnologia Made in Italy

IT

Dal 1955 il Gruppo Varvel progetta e realizza riduttori e variatori per applicazioni fisse di piccola e media potenza. Partner affidabile nella produzione e vendita di organi di trasmissione grazie a un elevato livello di servizio, offre anche soluzioni personalizzate operando nel rispetto dei valori dell'impresa socialmente responsabile. Modularità e flessibilità guidano la progettazione dei prodotti Varvel nella realizzazione di kit comuni a tutte le famiglie di riduttori, agevolando così l'attività di distributori e rivenditori che possono configurare in pochi minuti il prodotto richiesto dal singolo cliente.

## Technology Made in Italy

EN

Since 1955 the Varvel Group has been making gearboxes and variators for light industry applications. Reliable partner in power transmission equipment offers also customized solutions always according to a socially responsible company values. Modularity and flexibility lead Varvel products by a unique kit form, common to all gearbox series. This feature allows distributors an easier job to set up required products in few minutes.

## Technologie Made in Italy

DE

Seit 1955 plant und stellt die Varvel-Gruppe Getriebe und Verstellgetriebe für feste Kleinleistungsanwendungen her. Dank dem hohen Dienstniveau ist Varvel ein zuverlässiger Partner für Herstellung und Verkauf von Getriebewerkteilen und bietet maßgeschneiderte Lösungen an, in Verbindung mit sozialverträglicher Handlungsweise. Modularität und Flexibilität sind Kennzeichen für Varvel-Produkte. Die Firma produziert Teile, die sich für alle Getriebetypen eignen. Verteiler und Verkäufer können somit den Kundenanforderungen gerecht werden.



- UNI EN ISO 9001:2008
- UNI EN ISO 14001:2004
- BS OHSAS 18001:2007



- EC DIRECTIVE 2014/34/EU (ATEX)





**RIDUTTORI A VITE SENZA FINE E INGRANAGGI**  
per sistemi d'allevamento

**WORM AND HELICAL SPEED REDUCERS**  
for agricultural application

**SCHNECKEN- UND STIRNRADGETRIEBE**  
für Landwirtschaft und Tierhaltung



## Riduttori - Gearboxes - Getriebe

### Sistema modulare - Modular System - Modularsystem



Sistemi di gabbie  
Cage system  
Anlagen für die Käfighaltung



Sistemi per l'alimentazione avicola  
Poultry feeding systems  
Fütterungsanlagen für die Bodenhaltung

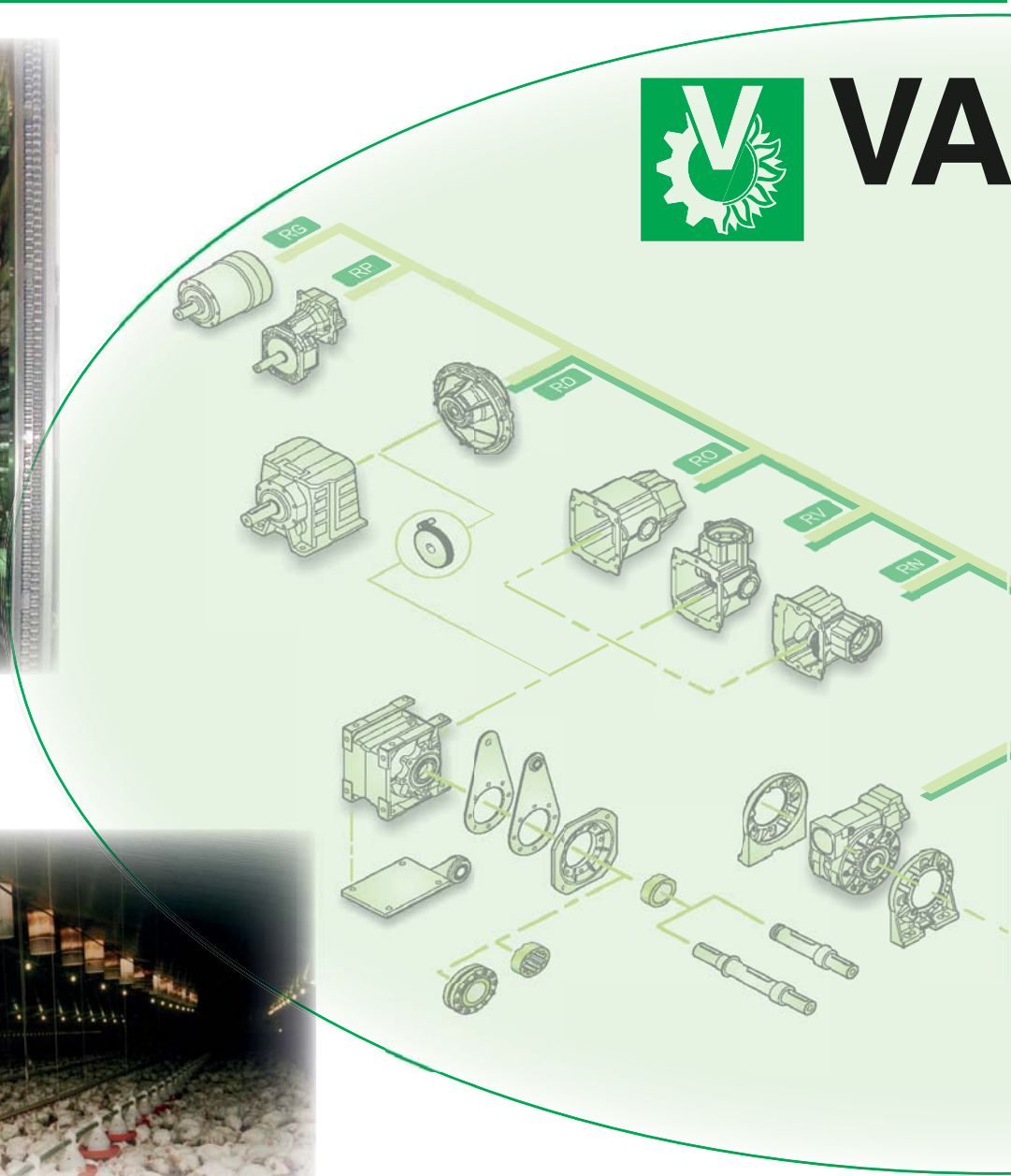

Trasportatori e raccolta uova  
Egg conveyors  
Eier Förder- und Sortieranlagen

# Getriebe - Gearboxes - Riduttori

## Modularsystem - Modular System - Sistema modulare

# Rfarm

by VARVEL

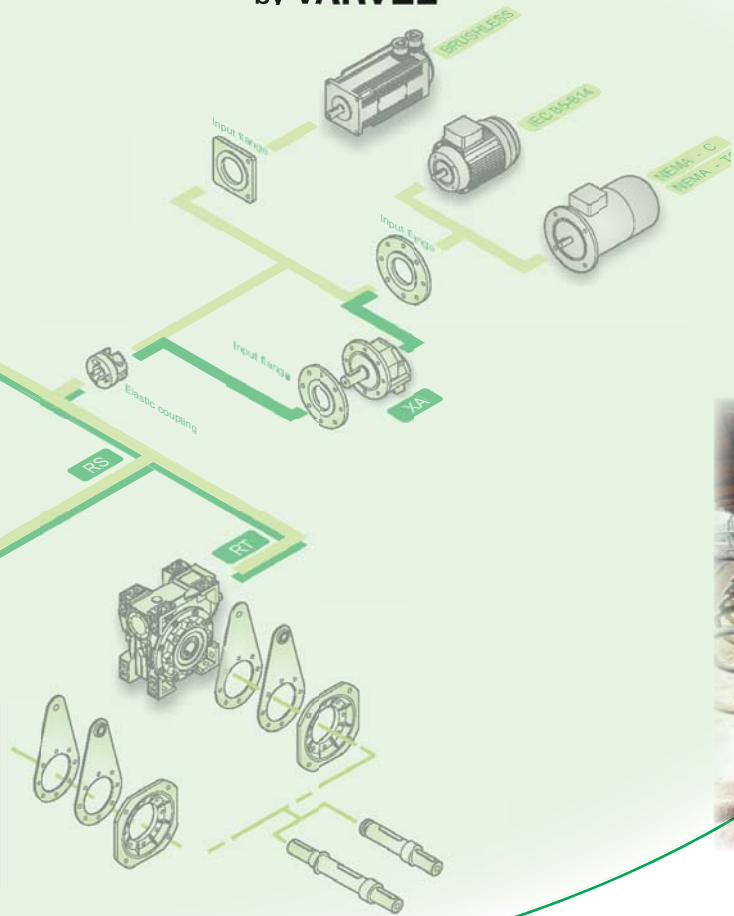

Raschiatori  
Scrapers  
Entmistungsanlage



Spazzole rotanti  
Cow Brushes  
Kuh Bürstenmaschinen



Sistemi per l'alimentazione suina  
Pig feeding systems  
Fütterungsanlagen für Schweine

## Giunto elastico "G" - Elastic coupling "G" - Elastische Kupplung "G"

L'utilizzo del **giunto elastico "G"** in sostituzione al tradizionale accoppiamento albero/linguetta tra motore e riduttore, introduce molteplici vantaggi mantenendo invariato l'ingombro complessivo del riduttore stesso.

The introduction of **flexible cou-pling "G type"** as replacement of traditional shaft/key fitting between motor and gearbox, gives various advantages but keeping unchanged gearbox overall dimensions.

Die Einführung der **flexiblen Kupplung "G-Typ"** als Ersatz zur traditionellen Welle/Passfeder Montage zwischen Motor und Getriebe, hat verschiedene Vorteile, bei unveränderten Abmessungen des Getriebe.

### Vantaggi

- Un solo riduttore per rapporto
- Maggiore flessibilità
- Rotazione stock aumentata
- Eliminazione dell'ossidazione per sfregamento (tribocorrosione)
- Gioco "zero" nel collegamento
- Disallineamento angolare 1° max
- Rigidità torsionale
- Smorzamento vibrazioni

### Advantages

- One gearbox only for each ratio
- Greater flexibility
- Increased stock rotation
- Fretting corrosion elimination
- Coupling zero backlash
- Angular misalignment 1deg. max.
- Torsional rigidity
- Vibration damping

### Vorzüge

- nur eine Getriebekomponente je Übersetzung
- gesteigerte Flexibilität
- höherer Lagerumschlag
- Vermeidung von Passungsrost
- spielfrei Verbindung
- Winkelausgleich bis 1°
- Verdrehsteifigkeit
- Dämpfung von Schwingungen

<b>Anello elastico</b>	Elastomero termoplastico
<b>Spider</b>	Thermoplastic elastomer
<b>Kupplungsscheibe</b>	Thermoplastic Elaste

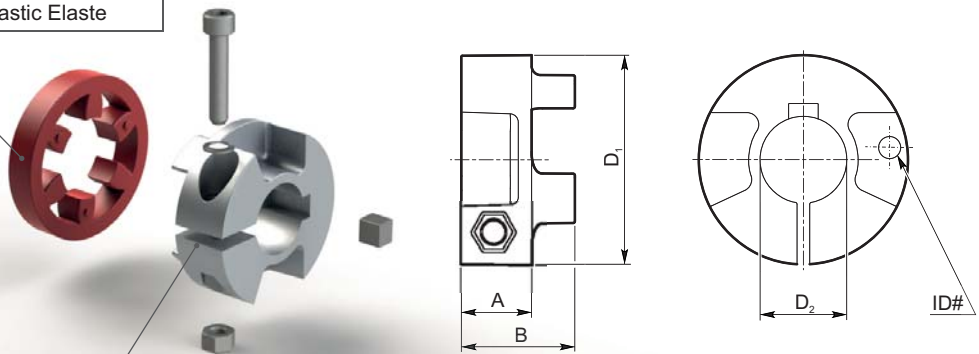

<b>Semigiunto motore</b>	Alluminio pressofuso (*Acciaio)
<b>Motor half-coupling</b>	Alu pressure die cast (*Steel)
<b>Motorkupplungshäfte</b>	Aluminium Druckguss (*Stahl)

Giunto Coupling Kupplung	IEC	Codice kit Kit code Kit Code	RD	RS-RT	RP	M <sub>t</sub> [Nm]	M <sub>t1</sub> [Nm]	M <sub>t2</sub> [Nm]	A [mm]	B [mm]	D <sub>1</sub> [mm]	D <sub>2</sub> [mm]	ID#
<b>G3</b>	IEC	KG3.009	03	28-40	---	4.5 - 6	15	8 - 10	11	19	30	9	309
		KG3.011	03	28-40	---	4.5 - 6	15	8 - 10			30	11	311
		KG3.014	03	40	---	7 - 8.5	28	18 - 22			36	14	314
<b>G5</b>	IEC	KG5.009	02-12-13-23	---	---	8.9 - 10	14	8 - 10	14.5	23	45	9	509
		KG5.011	02-12-13-23	50-60	---		15	8 - 10			45	11	511
		KG5.014	02-12-13-23	50-60	90		30	12 - 17			45	14	514
		KG5.019	02-12-23	50-60	90		40	20 - 25			45	19	519
		KG5.024	12-23	60	90		70	30 - 40			52	24	524
<b>G6</b>	IEC	KG6.014	22-32-33-42-43	70	---	15.3 - 18	60	30 - 40	19.5	31.5	58	14	614
		KG6.019	22-32-33-42-43	70-85-110	---		90	50 - 65			19	619	
		KG6.024	22-32-33-42-43	70-85-110	---		130	85 - 100			24	624	
		KG6.028	22-32-42	70-85-110	---		180	100 - 120			28	628	
<b>*GS8</b>	IEC	*KGS8.19	52-53-62-63	---	---	15	150	---	35	51	79	19	819
		*KGS8.24	52-53-62-63	---	---		250	---			24	824	
		*KGS8.28	52-53-62-63	---	---		350	---			28	828	
		*KGS8.38	52-62-63	---	---		500	---			38	838	
		*KGS8.42	52-62	---	---		500	---			42	842	
		*KGS8.48	52-62	---	---		500	---			48	848	

**RP**

**RIDUTTORI A INGRANAGGI A UNA COPPIA  
SINGLE STAGE HELICAL GEARBOXES  
EINSTUFIGE STIRNRADGETRIEBE**



# RP Riduttori - Gearboxes - Getriebe

## Dati tecnici - Technical data - Technische Daten

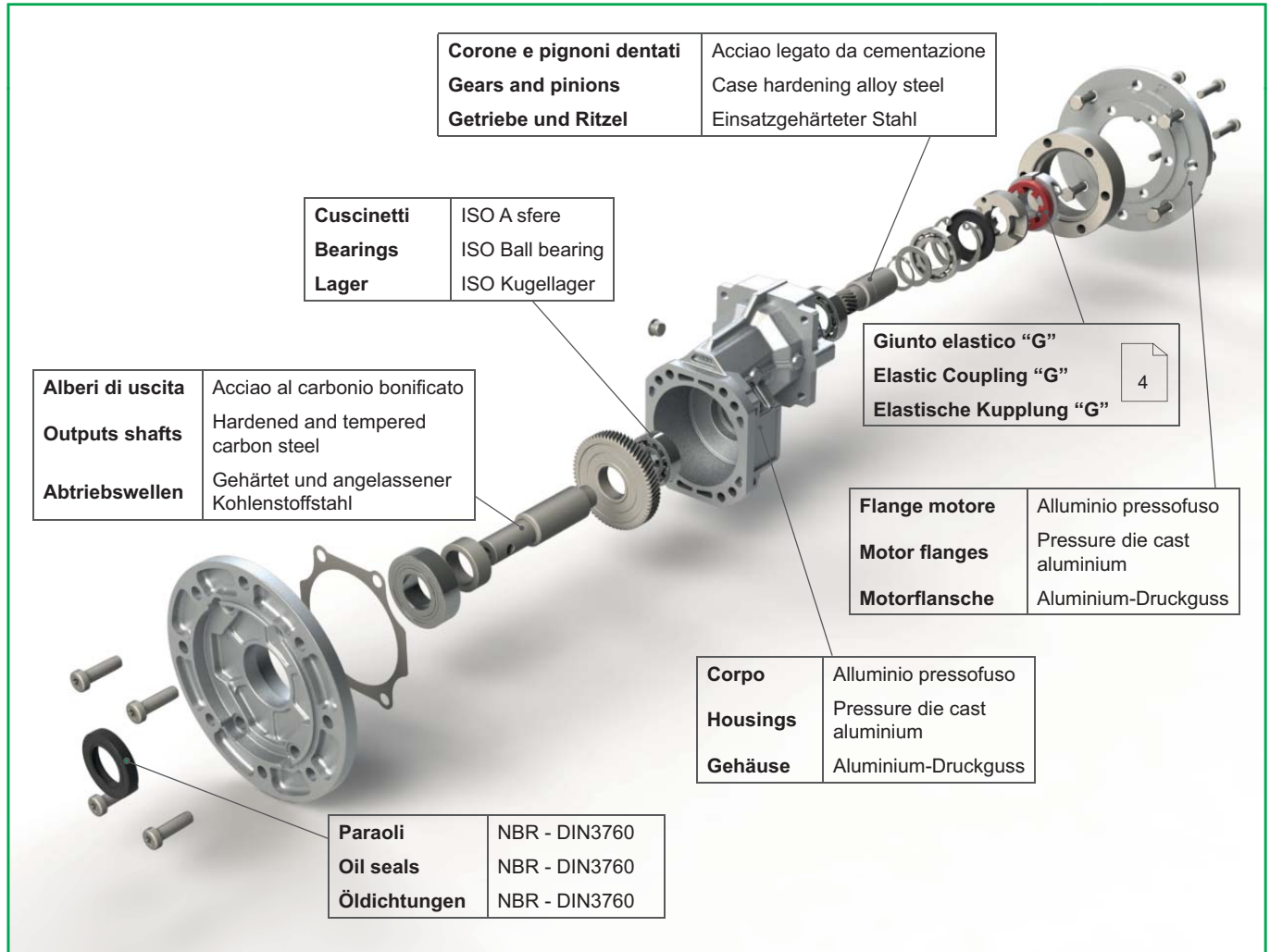

## Designazione - Designation - Bezeichnungen

<b>F</b>	<b>RP-G</b>	<b>90</b>	<b>B5/160</b>	<b>3.94</b>	<b>IEC80</b>	<b>B14</b>	<b>910.001</b>
M	RP-G	90	B5	2.52	IEC71	B5	10-11 Albero Uscita - Output shaft - Abtriebswelle
F			B5/1	..	IEC71	B14	
S			SQ	..	IEC80		
..			SQ/1	..	IEC80		
			B5/140	..	IEC90		
			B5/160	7.91	IEC90		
			8-9	7	9		Forma motore elettrico - Motor size - Motorbauform
							Grandezza IEC motore elettrico - IEC Motor size - IEC Motorbaugröße
							Rapporto di riduzione - Reduction ratio - Untersetzungsverhältnis
							Flangia uscita e diametro - Output flange and diameter - Abtriebsflansch und Durchmesser
							Grandezza del riduttore - Gearbox size - Getriebegröße
							Tipo di riduttore - Gearbox type - Getriebetyp

M = Motoriduttore - Geared Motor - Getriebemotor

F = Riduttore con flangia di entrata - Gearbox with input flange - Getriebe mit Eingangsflansch

S = Riduttore senza flangia di entrata - Gearbox without input flange - Getriebe ohne Eingangsflansch

.. = Riduttore con albero di entrata sporgente - Gearbox with input free shaft - Getriebe mit freie Eingangswelle



## Getriebe - Gearboxes - Riduttori RP

### Technische Daten - Technical data - Dati tecnici

	P <sub>1</sub> [kW]	i <sub>r</sub>	n <sub>2</sub> [rpm]	M <sub>2</sub> [Nm]	FS
1400 rpm / 50 Hz	0,25	2.52	556	4.2	8.3
		2.95	475	4.9	6.7
		3.2	438	5.3	6.2
		3.94	355	6.6	4.6
		4.25	329	7.1	4.1
		4.73	296	7.9	3.7
		5.07	276	8.5	3.3
		5.7	246	9.5	2.6
		7.0	200	11.7	2.0
	7.91	177	13.2	1.6	
	0,37	2.52	556	6.2	5.6
		2.95	475	7.3	4.5
		3.2	438	7.9	4.2
		3.94	355	9.7	3.1
		4.25	329	10.5	2.8
		4.73	296	11.7	2.5
		5.07	276	12.5	2.2
		5.7	246	14.1	1.8
		7.0	200	17.3	1.3
	7.91	177	19.6	1.1	
	0,55	2.52	556	9.3	3.8
		2.95	475	10.8	3.0
		3.2	438	11.8	2.8
		3.94	355	14.5	2.1
		4.25	329	15.6	1.9
		4.73	296	17.4	1.7
		5.07	276	18.6	1.5
		5.7	246	21.0	1.2
		7.0	200	25.7	0.9
	0,75	2.52	556	12.6	2.8
		2.95	475	14.8	2.3
		3.2	438	16.0	2.1
		3.94	355	19.8	1.5
		4.25	329	21.3	1.3
		4.73	296	23.7	1.2
		5.07	276	25.4	1.1
5.7		246	28.6	0.9	
1,1		2.52	556	18.5	1.6
	2.95	475	21.7	1.4	
	3.2	438	23.5	1.3	
	3.94	355	29.0	1.0	
	4.25	329	31.3	0.9	
1,5	4.73	296	34.8	0.8	
	5.07	276	37.3	0.8	
	2.52	556	25.3	1.2	
	2.95	475	29.6	1.0	
		3.2	438	32.1	0.8

	P <sub>1</sub> [kW]	i <sub>r</sub>	n <sub>2</sub> [rpm]	M <sub>2</sub> [Nm]	FS
1750 rpm / 60 Hz	0,25	2.52	694	3.4	10.4
		2.95	593	3.9	8.4
		3.2	547	4.3	7.8
		3.94	444	5.3	5.8
		4.25	412	5.7	5.1
		4.73	370	6.3	4.6
		5.07	345	6.8	4.1
		5.7	307	7.6	3.3
		7.0	250	9.4	2.5
	7.91	221	10.6	2.0	
	0,37	2.52	694	5.0	7.0
		2.95	593	5.8	5.6
		3.2	547	6.3	5.3
		3.94	444	7.8	3.9
		4.25	412	8.4	3.5
		4.73	370	9.4	3.1
		5.07	345	10.0	2.8
		5.7	307	11.3	2.3
		7.0	250	13.9	1.6
	7.91	221	15.7	1.4	
	0,55	2.52	694	7.4	4.8
		2.95	593	8.7	3.8
		3.2	547	9.4	3.5
		3.94	444	11.6	2.6
		4.25	412	12.5	2.4
		4.73	370	13.9	2.1
		5.07	345	14.9	1.9
		5.7	307	16.8	1.5
		7.0	250	20.6	1.1
	7.91	221	23.3	1.0	
	0,75	2.52	694	10.1	3.5
		2.95	593	11.8	2.9
		3.2	547	12.8	2.6
		3.94	444	15.8	1.9
		4.25	412	17.0	1.6
		4.73	370	19.0	1.5
5.07		345	20.3	1.4	
5.7		307	22.9	1.1	
7.0		250	28.1	0.9	
7.91	221	31.7	0.8		
1,1	2.52	694	14.8	2.0	
	2.95	593	17.4	1.8	
	3.2	547	18.8	1.6	
	3.94	444	23.2	1.3	
	4.25	412	25.0	1.1	
	4.73	370	27.8	1.0	
1,5	5.07	345	29.8	1.0	
	5.7	307	33.5	0.8	
	2.52	694	20.2	1.5	
	2.95	593	23.7	1.3	
	3.2	547	25.7	1.0	
		3.94	444	31.6	0.8

# RP Riduttori - Gearboxes - Getriebe

## Dimensioni - Dimensions - Abmessungen

### Riduttori e flange di uscita - Gearboxes and output flange - Getriebe und Abtriebsflansche

**FRP-G 90 B5**

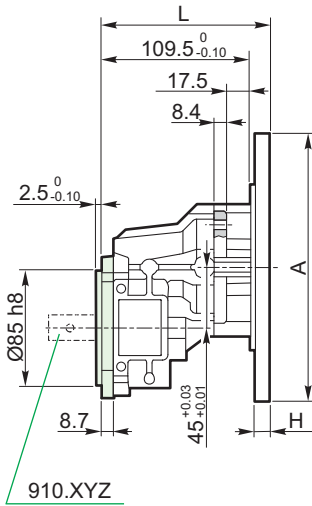

**FRP-G 90 B5/1**

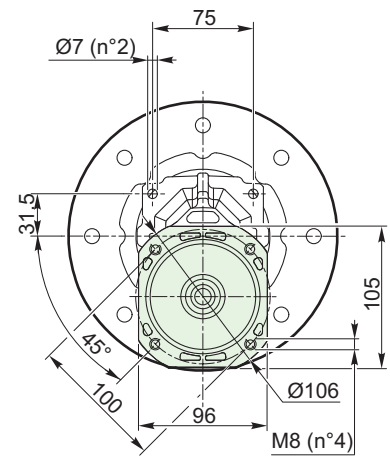
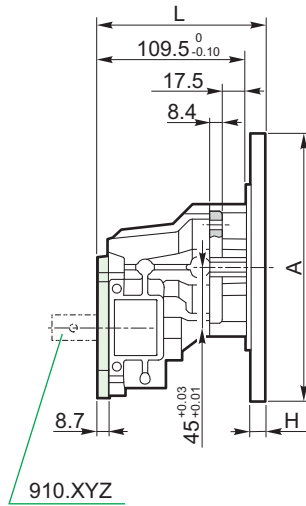

**FRP-G 90 SQ**

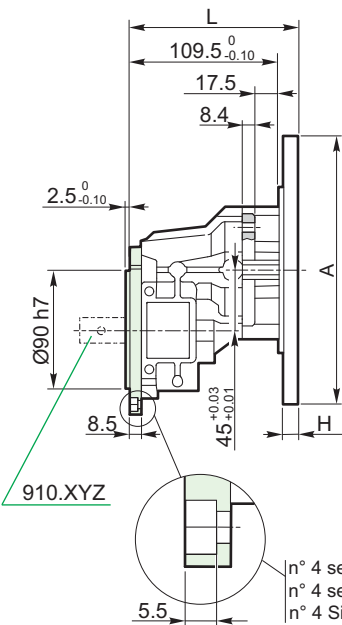

**FRP-G 90 SQ/1**

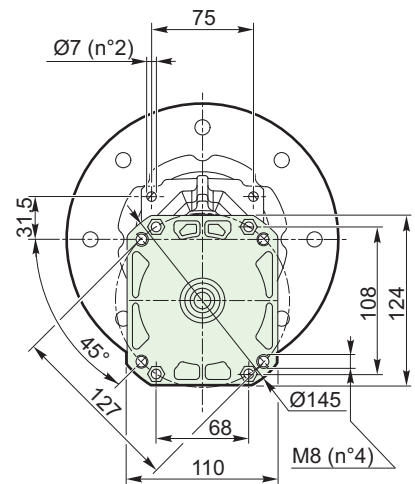
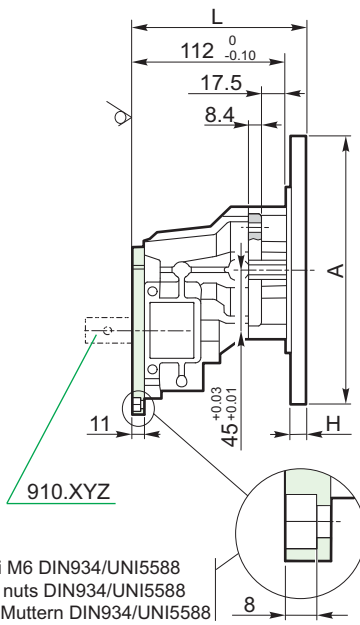

n° 4 sedi per dadi M6 DIN934/UNI5588  
n° 4 seats for M6 nuts DIN934/UNI5588  
n° 4 Sitze für M6 Muttern DIN934/UNI5588

# Getriebe - Gearboxes - Riduttori RP

## Abmessungen - Dimensions - Dimensioni

### FRP-G 90 B5/140

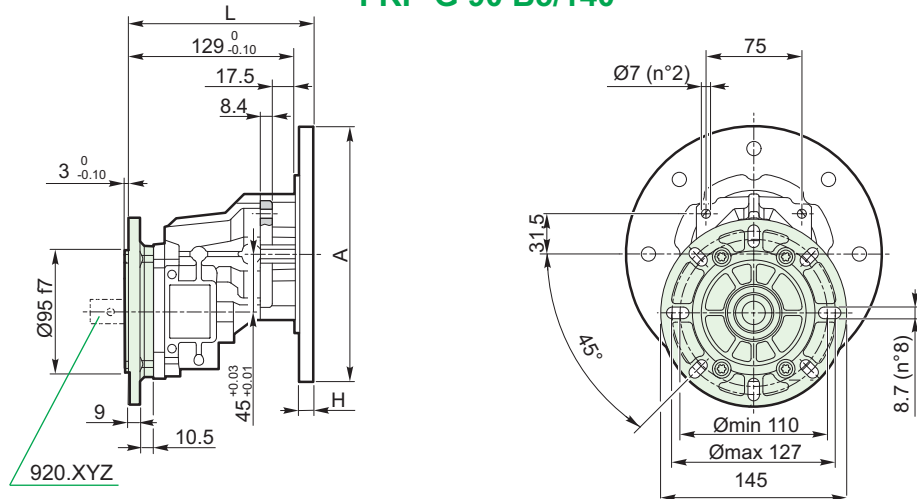

### FRP-G 90 B5/160

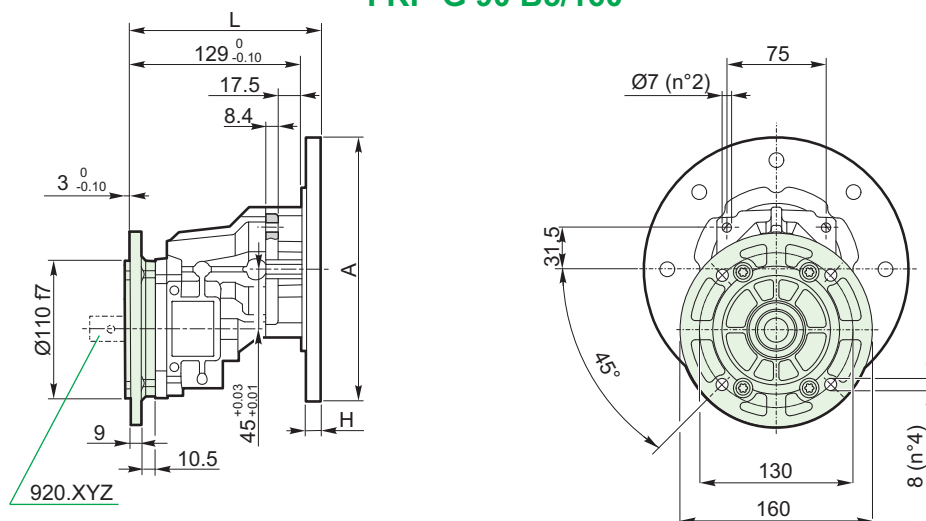

### IEC Motorflanschen - IEC motor flanges - Flange motore IEC

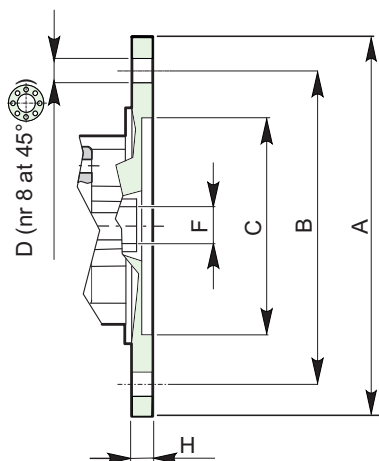

		71B5	71B14	80B5	80B14	90B5	90B14
	<b>A</b>	160	105	200	120	200	140
	<b>B</b>	130	85	165	100	165	115
	<b>C</b>	110	70	130	80	130	95
	<b>D</b>	10	7	11	7	11	10
	<b>F</b>	14	14	19	19	24	24
	<b>H</b>	11.5	10.5	11.5	10	11.5	11
FRP90 B5 FRP90 B5/1 FRP90 SQ	<b>L</b>	125	125	125	127	150	152
FRP90 SQ/1		127.5	127.5	127.5	129.5	152.5	154.5
FRP90 B5/140 FRP90 B5/160		144.5	144.5	144.5	146.5	169.5	171.5

# RP Riduttori - Gearboxes - Getriebe

## Dimensioni - Dimensions - Abmessungen

### Alberi di uscita - Output shafts - Abtriebswellen

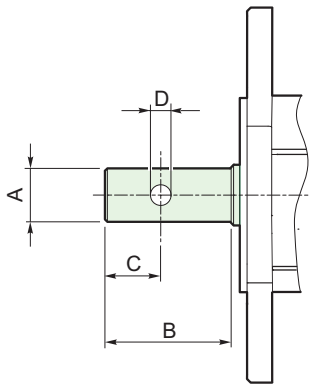

A	B	C	D (H11)	Codice albero Shaft ID Teilenummer Welle
ø16 <sup>0</sup> <sub>-0.05</sub>	50	21	6.5	910.007
ø16 <sup>0</sup> <sub>-0.05</sub>	50	21	7	910.018
ø18.8 <sup>0</sup> <sub>-0.1</sub>	80	15	8.5	920.008
ø19 <sup>0</sup> <sub>-0.05</sub>	57	23	6.5	910.001
ø19 <sup>0</sup> <sub>-0.05</sub>	57	23	6.5	910.017
ø19 <sup>h7</sup>	40	14	6.5	920.006
ø19.7 <sup>+0.05</sup> <sub>-0.05</sub>	100	50	6	920.016
ø20 <sup>h7</sup>	84	30	6	920.013
ø20 <sup>0</sup> <sub>-0.2</sub>	52	23	6.5	920.022
ø21 <sup>0</sup> <sub>-0.1</sub>	52	23	6	920.012
ø21 <sup>0</sup> <sub>-0.05</sub>	57	23	6	910.024
ø22 <sup>0</sup> <sub>-0.1</sub>	80	15	8.5	920.011
ø22 <sup>0</sup> <sub>-0.05</sub>	57	23	8.5	910.004

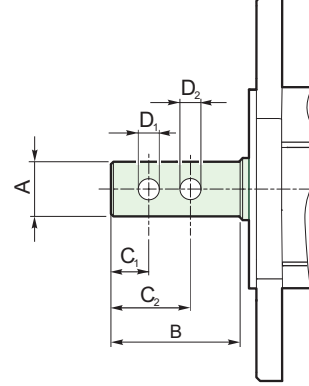

A	B	C <sub>1</sub>	C <sub>2</sub>	D <sub>1</sub> (H11)	D <sub>2</sub> (H11)	Codice albero Shaft ID Teilenummer Welle
ø19 <sup>0</sup> <sub>-0.05</sub>	57	23	38	6.5	6.5	910.015
ø19 <sup>0</sup> <sub>-0.2</sub>	92	30	48	8.5	8.5	910.002
ø19.7 <sup>+0.05</sup> <sub>-0.05</sub>	100	30	50	6	6	910.014
ø20 <sup>0</sup> <sub>-0.05</sub>	75	37	53	7	7	910.005
ø20 <sup>h7</sup>	72	20	40	8	6.5	920.023
ø22 <sup>0</sup> <sub>-0.2</sub>	52	23	38	6.5	6.5	910.009

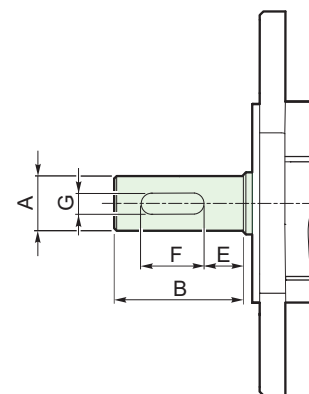

A	B	E	F	G	Codice albero Shaft ID Teilenummer Welle
					910.003
ø19 <sup>h6</sup>	40	5	30	6	910.019
					920.003

**Nota:** Selezione albero/flange uscita: vedere pag.

**Note:** Output shaft/flange selection: see pag.

**Notiz:** Notiz: Auswahl der Ausgangswellen und Flansche: s. Seite

[www.reduktor-varvel.ru](http://www.reduktor-varvel.ru)

# Getriebe - Gearboxes - Riduttori RP

## Abmessungen - Dimensions - Dimensioni

### Abtriebsflansche - Output flanges - Flange di uscita

Codice albero Shaft ID Welle teilenummer	Flangia di uscita Output flange Abtriebsflansche				Quota di spallamento Shoulder value Schulter-Wert			
	B5 B5/1	SQ SQ/1	B5/140	B5/160	H <sub>1</sub>	H <sub>2</sub>	H <sub>3</sub> *	H <sub>4</sub> *
910.001	•	•			2.5		0	
910.002	•	•			0			2.5
910.003	•	•			0			2.5
920.003			•	•		9		
910.004	•	•			2.5		0	
910.005	•	•			2.5		0	
920.006			•	•		7.5		
910.007	•	•			3.5		1.0	
920.008			•	•		9		
910.009	•	•			4.5		2.0	
920.011			•	•		9		
920.012			•	•		9		
920.013			•	•	4.5			
910.014	•	•			4.5		2.0	
910.015	•	•			2.5		0	
920.016			•	•		9		
910.017	•	•			5.5		3.0	
910.018	•	•			3.5		1.0	
910.019	•	•			4.5		2.0	
920.022			•	•		9		
920.023			•	•	0			
910.024	•	•			2.5		0	

Altre estremità d'albero a richiesta - Other shaft ends on demand - weitere Ausgangswellen auf Anfrage

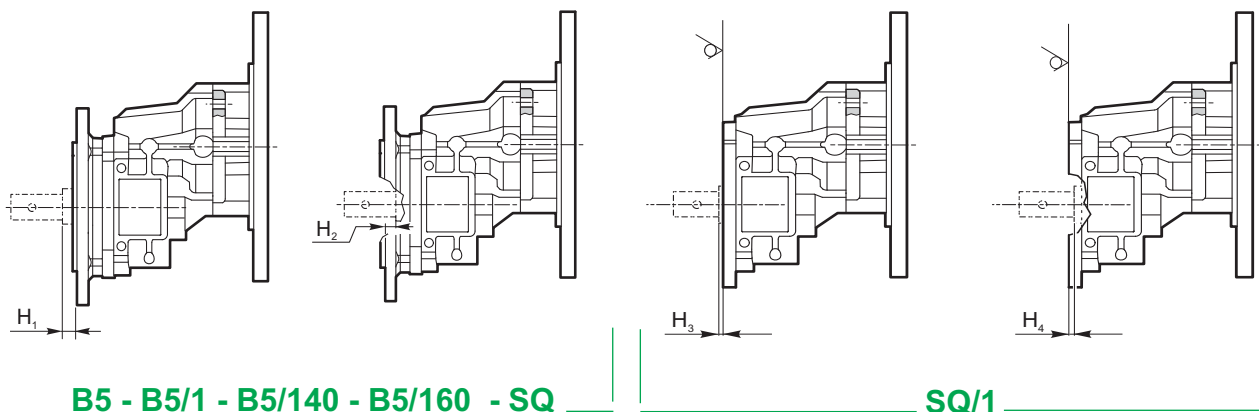

\* Quota H<sub>3</sub> e H<sub>4</sub> solo per versioni con flange SQ/1 - Dimensions H<sub>3</sub> and H<sub>4</sub> for flange SQ/1 only - Abmessungen H<sub>3</sub> und H<sub>4</sub> nur Für Flansch SQ/1

# Motori - Motors - Motoren

## Designazione - Designation - Bezeichnungen

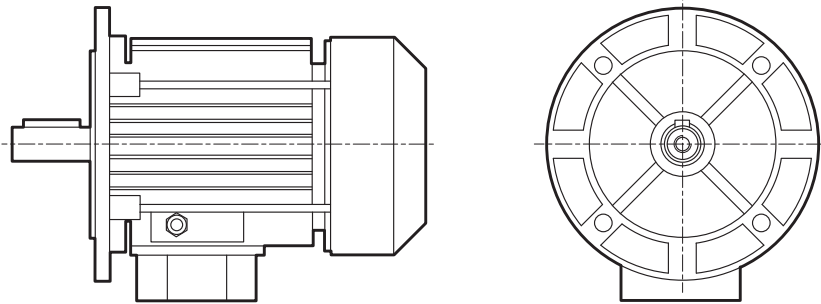

### Motore - Motor - Motor RP - RD - RS - RT

<b>MT</b>	<b>0.37 kW</b>	<b>71B</b>	<b>4</b>	<b>B14</b>	<b>230/400/50</b>	<b>IP55</b>	<b>F</b>	<b>X4</b>
MT	0.06	56		B5				X1
MM	..	..		B14				X2
MA	..	..						X3
	..	..						X4
	15	160						

Posizione morsetteria - Terminal box position - Klemmkastenposition

Classe d'isolamento - Insulation class - Isolationsklasse  
Class F (std)

Grado di protezione - Protection class - Schutzart  
IP55 (std)

Tensione/frequenza - Voltage/frequency - Spannung/Frequenz

Forma costruttiva - Mounting form - Bauform

Numero poli - Number of poles - Polzahl

Grandezza IEC motore - IEC motor frame - IEC Motorbaugröße

Potenza motore - Motor power - Motorleistung

MT = Motore trifase - Three-phase motor - Dreiphasenmotor

MM = Motore monofase - Single-phase motor - Einphasenmotor

MA = Motore autofrenante - Brake motor - Bremsmotor

### Posizione morsetteria - Terminal position - Klemmenkastenlage position

**RP**

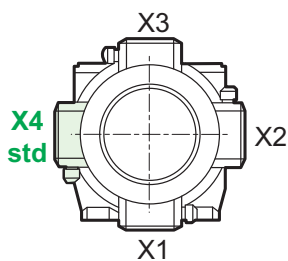

**RD**

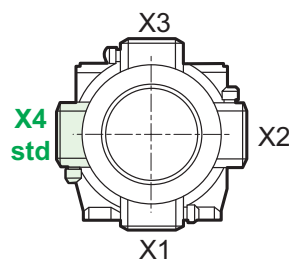

**RS**

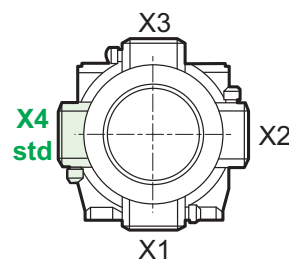

**RT**

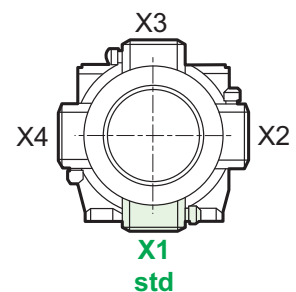

# RD

**RIDUTTORI A INGRANAGGI - DUE E TRE COPPIE  
TWO AND THREE STAGE HELICAL GEARBOXES  
ZWEI- UND DREISTUFIGE STIRNRADGETRIEBE**



# RD Riduttori - Gearboxes - Getriebe

## Dati tecnici - Technical data - Technische Daten

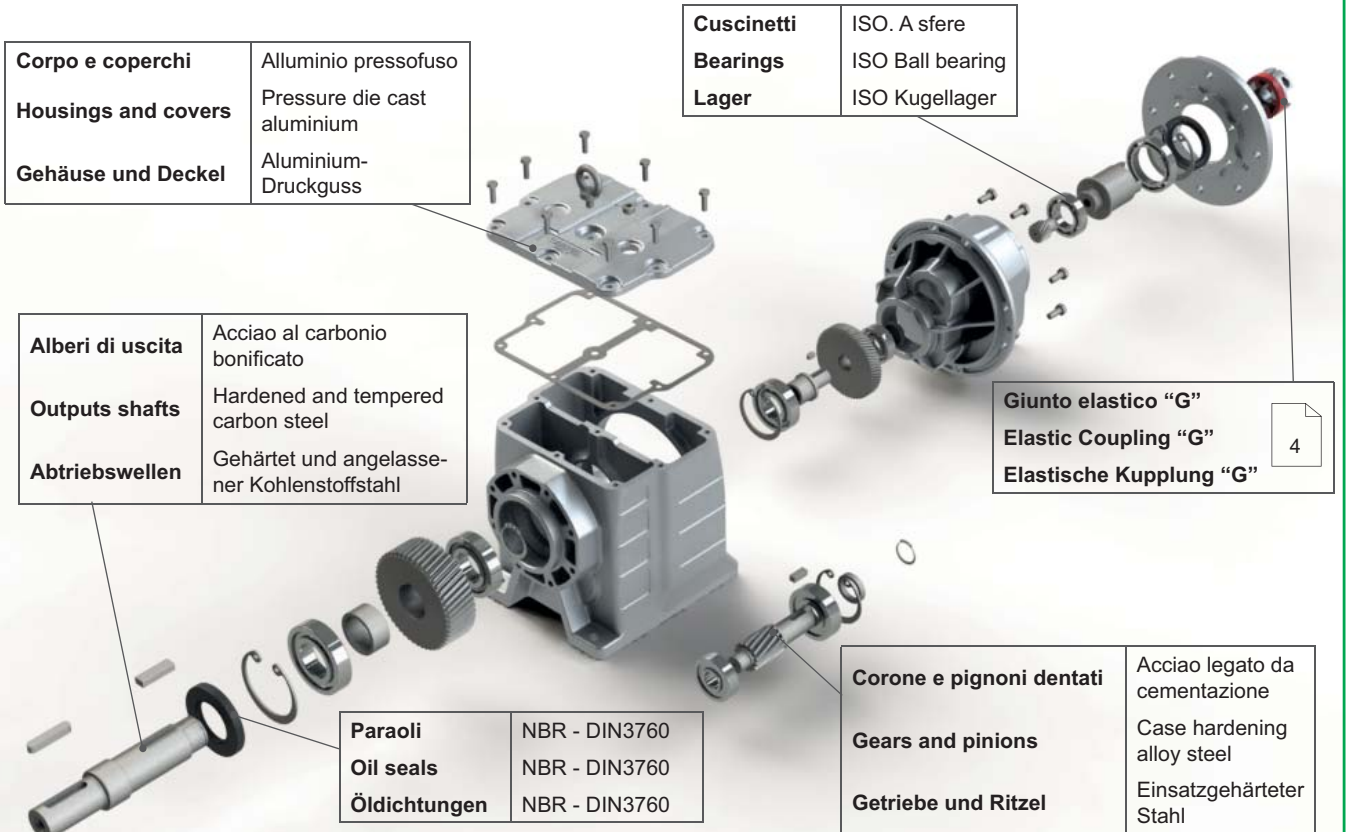

<b>Corpo e coperchi</b>	Alluminio pressofuso	<b>Cuscinetti</b>	ISO. A sfere
<b>Housings and covers</b>	Pressure die cast aluminium	<b>Bearings</b>	ISO Ball bearing
<b>Gehäuse und Deckel</b>	Aluminium-Druckguss	<b>Lager</b>	ISO Kugellager
<b>Alberi di uscita</b>	Acciaio al carbonio bonificato	<b>Giunto elastico "G"</b>	
<b>Outputs shafts</b>	Hardened and tempered carbon steel	Elastic Coupling "G"	
<b>Abtriebswellen</b>	Gehärtet und angelassener Kohlenstoffstahl	Elastische Kupplung "G"	
<b>Paraoli</b>	NBR - DIN3760	<b>Corone e pignoni dentati</b>	
<b>Oil seals</b>	NBR - DIN3760	Acciaio legato da cementazione	
<b>Öldichtungen</b>	NBR - DIN3760	<b>Gears and pinions</b>	
		Case hardening alloy steel	
		<b>Getriebe und Ritzel</b>	
		Einsatzgehärteter Stahl	

## Designazione - Designation - Bezeichnungen

<b>F</b>	<b>RD</b>	<b>3</b>	<b>2</b>	<b>/B3</b>	<b>H</b>	<b>6.3</b>	<b>IEC71</b>	<b>-B14</b>	<b>AU30</b>	<b>DFU200</b>
M	RD	0	2	B3	H	2.25	56	B5		
F		1	3	B5	V	..	63	B14		
S		2				..	71			
..		3				..	80			
		4				..	90			
		5				630	100			
		6					112			
							132			

Flangia di uscita  $\varnothing$  - Output flange  $\varnothing$  - Ausgangsflansch  $\varnothing$   
 Albero di uscita  $\varnothing$  - Output shaft  $\varnothing$  - Ausgangswelle  $\varnothing$   
 Forma motore elettrico - Motor size - Motorbaufom  
 Grandezza IEC motore elettrico - IEC motor size - IEC Motorbaugröße  
 Rapporto di riduzione - Reduction ratio - Getriebeübersetzung  
 Forma di montaggio riduttore - Gearbox mounting position- Einbaulage des Getriebes  
 Forma costruttiva riduttore - Gearbox form - Bauform des Getriebes  
 Numero coppie di riduzione - Number of reduction stages - Anzahl der Getrebestufen  
 Grandezza del riduttore - Gearbox size - Getriebegröße  
 Tipo di riduttore - Gearbox type - Getriebetyp

M = Motoriduttore - Geared Motor - Getriebemotor  
 F = Riduttore con flangia di entrata - Gearbox with input flange - Getriebe mit Eingangsflansch  
 S = Riduttore senza flangia di entrata - Gearbox without input flange - Getriebe ohne Eingangsflansch  
 .. = Riduttore con albero di entrata sporgente - Gearbox with input free shaft - Getriebe mit freie Eingangswelle





## Getriebe - Gearboxes - Riduttori RD

$n_1 = 1400$  rpm

Technische Daten - Technical data - Dati tecnici

$i_n$	RD0			RD1			RD2			RD3		
	$n_2$ [rpm]	$P_1$ [kW]	$M_2$ [Nm]	$n_2$ [rpm]	$P_1$ [kW]	$M_2$ [Nm]	$n_2$ [rpm]	$P_1$ [kW]	$M_2$ [Nm]	$n_2$ [rpm]	$P_1$ [kW]	$M_2$ [Nm]
2.5	545	1.8	30	560	2.5	45	560	5.0	85	560	10.5	190
3.15	427	1.8	33	445	2.2	45	445	4.4	90	445	9.2	205
4.0	329	1.3	36	350	1.8	50	350	3.8	100	350	7.9	220
5.0	265	1.1	38	280	1.6	55	280	3.1	105	280	6.6	235
6.3	234	1.2	48	220	2.1	90	220	4.1	175	220	9.3	370
8.0	175	1.0	49	175	1.7	90	175	3.4	180	175	7.6	370
10.0	135	0.8	50	140	1.3	90	140	2.7	180	140	6.2	375
12.5	100	0.8	50	110	1.1	90	110	2.2	180	110	4.9	380
16.0	86	0.5	61	90	0.9	90	90	1.8	185	90	3.7	390
20.0	65	0.4	51	70	0.7	90	70	1.4	190	70	3.2	390
25.0	52	0.3	52	55	0.6	95	55	1.1	190	55	2.5	395
31.5	46	0.3	52	45	0.5	95	45	1.0	190	45	1.7	400
40	40	0.2	35	35	0.3	70	35	0.5	140	35	1.1	285
50	33	0.1	35	30	0.2	70	30	0.4	140	30	0.9	285
63	---	---	---	22	0.2	70	22	0.3	140	22	0.7	285
40	37	0.2	52	35	0.4	95	35	0.8	200	35	1.7	420
50	30	0.2	52	30	0.3	95	30	0.6	200	30	1.3	420
63	23	0.1	52	22	0.2	95	22	0.5	200	22	1.0	420
80	18	0.1	52	18	0.2	100	18	0.4	200	18	0.9	420
100	15	0.1	52	14	0.2	100	14	0.3	200	14	0.7	425
125	11	0.1	52	11	0.1	100	11	0.3	200	11	0.5	425
160	9	0.1	52	9	0.1	100	9	0.2	200	9	0.4	425
180	8	0.05	52	---	---	---	---	---	---	---	---	---
200	7	0.03	36	7	0.1	100	7	0.2	200	7	0.3	425
250	5.5	0.02	36	5.5	0.1	100	5.5	0.1	200	5.5	0.3	430
280	5	0.02	36	---	---	---	---	---	---	---	---	---
315	4.3	0.02	36	4.5	0.1	100	4.5	0.1	200	4.5	0.2	430
400	---	---	---	3.5	0.03	70	3.5	0.1	140	3.5	0.1	290
500	---	---	---	2.8	0.02	70	2.8	0.04	140	2.8	0.1	290
630	---	---	---	2.2	0.02	70	2.2	0.04	140	2.2	0.1	290

 due coppie di riduzione - two-stage reduction ratios - zwei Stufen

 tre coppie di riduzione - three-stage reduction ratios - drei Stufen

**Rapporti fornibili a richiesta**  $i_n = 2.25 - 2.80 - 3.55 - 4.5 - 5.6 - 7.1 - 9.0$  tutte le grandezze,  $i_n = 35.5$  solo per RD0

**Ratios available on request**  $i_n = 2.25 - 2.80 - 3.55 - 4.5 - 5.6 - 7.1 - 9.0$  all sizes,  $i_n = 35.5$  only RD0

**Untersetzungen auf Anfrage**  $i_n = 2.25 - 2.80 - 3.55 - 4.5 - 5.6 - 7.1 - 9.0$  alle Größen,  $i_n = 35.5$  nur RD0

## RD Riduttori - Gearboxes - Getriebe

### Dati tecnici - Technical data - Technische Daten

 $n_1 = 1400 \text{ rpm}$ 

$i_n$	RD4			RD5			RD6		
	$n_2$ [rpm]	$P_1$ [kW]	$M_2$ [Nm]	$n_2$ [rpm]	$P_1$ [kW]	$M_2$ [Nm]	$n_2$ [rpm]	$P_1$ [kW]	$M_2$ [Nm]
2.5	560	17.7	300	560	34	630	560	70	1300
3.15	445	15.3	320	445	30	690	445	60	1400
4.0	350	14.2	380	350	29	750	350	58	1600
5.0	280	12.3	400	280	26.8	850	280	55.4	1800
6.3	220	15.2	620	220	27.4	1160	220	46.8	2000
8.0	175	12.3	620	175	21.8	1170	175	36.6	2000
10.0	140	9.8	620	140	18.1	1180	140	31.7	2100
12.5	110	8	620	110	14.8	1190	110	25.7	2100
16.0	90	6.6	650	90	11.8	1200	90	20.3	2100
20.0	70	5.7	650	70	9.1	1220	70	15.5	2100
25.0	55	4.2	650	55	7.2	1230	55	13.0	2100
31.5	45	3.5	650	45	6.0	1240	45	10.0	2220
40	35	1.5	450	35	3.2	850	35	6	1600
50	30	1.2	450	30	2.4	850	30	4.9	1600
63	22	1.1	450	22	1.9	850	22	4.3	1600
40	35	2.5	700	35	5.0	1270	35	8.6	2200
50	30	2.1	700	30	4.1	1280	30	7	2200
63	22	1.5	700	22	3.4	1290	22	5.5	2200
80	18	1.7	700	18	2.6	1300	18	4.4	2300
100	14	1.1	700	14	2.1	1300	14	3.7	2300
125	11	0.9	700	11	1.6	1300	11	3.4	2300
160	9	0.7	700	9	1.3	1300	9	2.8	2300
180	---	---	---	---	---	---	---	---	---
200	7	0.6	700	7	1.1	1300	7	1.8	2300
250	5.5	0.4	700	5.5	0.8	1300	5.5	1.4	2300
280	---	---	---	---	---	---	---	---	---
315	4.5	0.35	700	4.5	0.45	900	4.5	1.1	2300
400	3.5	0.22	460	3.5	0.35	900	3.5	1.6	2300
500	2.8	0.12	460	2.8	0.3	900	2.8	0.8	2300
630	2.2	0.11	460	2.2	0.25	900	2.2	0.7	2300

due coppie di riduzione - two-stage reduction ratios - zwei Stufen

tre coppie di riduzione - three-stage reduction ratios - drei Stufen

Rapporti fornibili a richiesta  $i_n = 2.25 - 2.80 - 3.55 - 4.5 - 5.6 - 7.1 - 9.0$  tutte le grandezze,  $i_n = 35.5$  solo per RD0

Ratios available on request  $i_n = 2.25 - 2.80 - 3.55 - 4.5 - 5.6 - 7.1 - 9.0$  all sizes,  $i_n = 35.5$  only RD0

Untersetzungen auf Anfrage  $i_n = 2.25 - 2.80 - 3.55 - 4.5 - 5.6 - 7.1 - 9.0$  alle Größen,  $i_n = 35.5$  nur RD0

# Getriebe - Gearboxes - Riduttori RD

## Abmessungen - Dimensions - Dimensioni

### B3

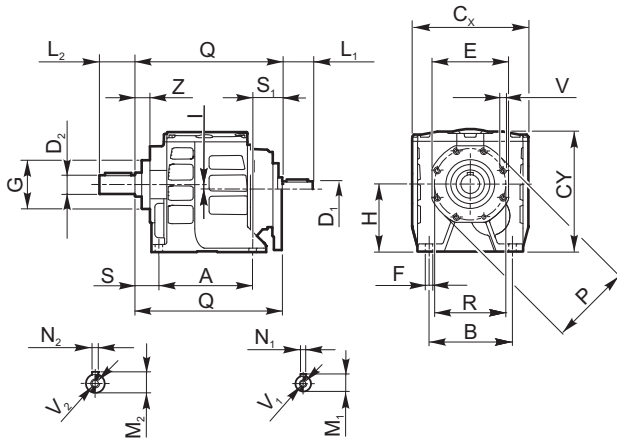

### B5

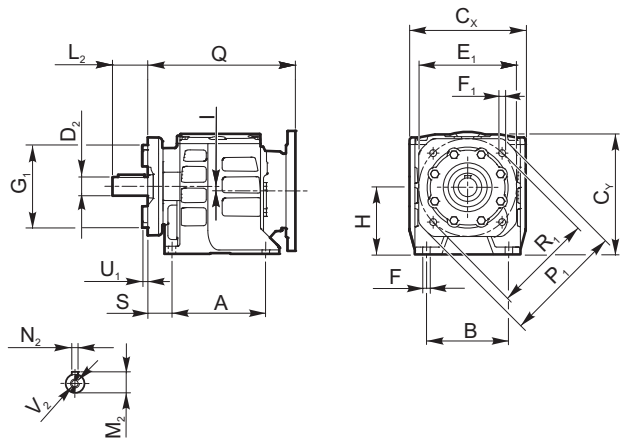

	RD02	RD03	RD12	RD13	RD22	RD23	RD32	RD33
<b>A</b>	95		110		130		165	
<b>B</b>	80		110		110		135	
<b>C<sub>x</sub></b>	100		140		155		190	
<b>C<sub>y</sub></b>	111		131		158		198	
<b>D<sub>1</sub> h6</b>	11		14		19		24	
<b>D<sub>2</sub> h6</b>	17 - 20		20 - 25		25 - 30		30 - 35	
<b>E</b>	82		82		102		125	
<b>E<sub>1</sub></b>	100 (115) [130]		100 (115) [130]		115 (130) [165]		130 (165) [215]	
<b>F</b>	9		9		9		11.5	
<b>F<sub>1</sub></b>	7 (9) [9]		7 (9) [9]		9 (9) [11]		9 (11) [13]	
<b>G g6</b>	60		60		65		85	
<b>G<sub>1</sub> h7</b>	80 (95) [110]		80 (95) [110]		95 (110) [130]		110 (130) [180]	
<b>H</b>	60		75		90		115	
<b>I</b>	4,5		5		6		8.5	
<b>L<sub>1</sub></b>	23		30		40		50	
<b>L<sub>2</sub></b>	35 (40)		40 (50)		50 (60)		60 (70)	
<b>M<sub>1</sub></b>	12.5		16		21.5		27	
<b>M<sub>2</sub></b>	19 - 22.5		22.5 - 28		28 - 33		33 - 38	
<b>N<sub>1</sub></b>	4		5		6		8	
<b>N<sub>2</sub></b>	5 - 6		6 - 8		8 - 8		8 - 10	
<b>P</b>	84		84		108		130	
<b>P<sub>1</sub></b>	120 (140) [160]		120 (140) [160]		140 (160) [200]		160 (200) [250]	
<b>Q</b>	140	143	151	161	190	208	220	253
<b>R</b>	75		75		95		115	
<b>R<sub>1</sub></b>	100 (115) [130]		100 (115) [130]		115 (130) [165]		130 (165) [215]	
<b>S</b>	20		18		25		30	
<b>S<sub>1</sub></b>	25	28	23	33	35	53	25	58
<b>U<sub>1</sub></b>	3 (3) [3]		3 (3) [3]		3 (3) [3]		3.5 (3.5) [3.5]	
<b>V</b>	M6x14 (n° 7)		M6x14 (n° 7)		M6x10 (n° 8)		M8x18 (n° 8)	
<b>V<sub>1</sub></b>	M5x12		M5x12		M6x16		M8x19	
<b>V<sub>2</sub></b>	M6x16 - M6x16		M6x16 - M6x16		M6x16 - M10x22		M10x22 - M10x22	
<b>Z</b>	13		10		13		13	
<b>Kg</b>	3.0	3.2	4.8	4.8	7.9	8.5	13.5	14.5

# RD Riduttori - Gearboxes - Getriebe

## Dimensioni - Dimensions - Abmessungen

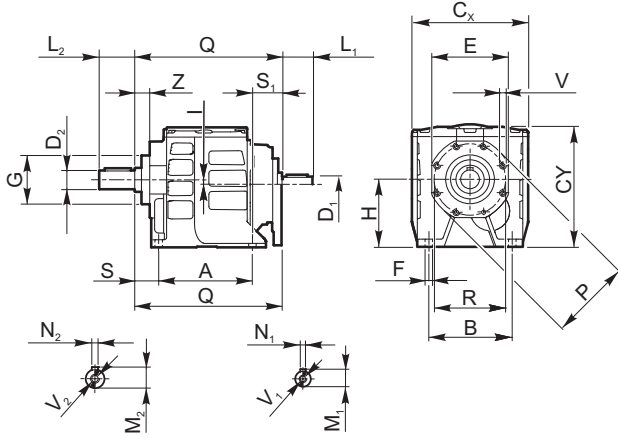
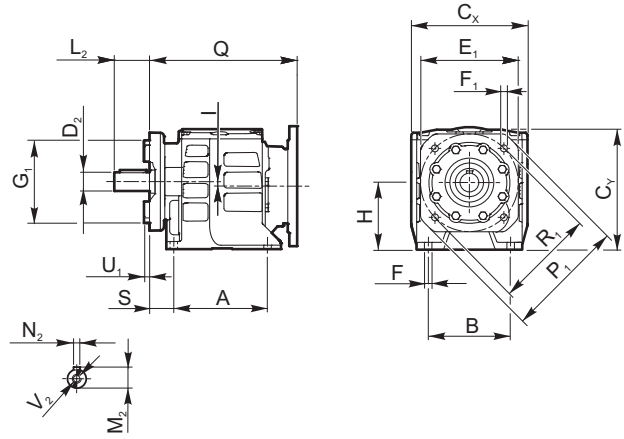
**B3**

**B5**

	RD42	RD43	RD52	RD53	RD62	RD63
<b>A</b>	195		205		260	
<b>B</b>	150		170		215	
<b>C<sub>x</sub></b>	215		284		340	
<b>C<sub>y</sub></b>	222		255		302	
<b>D<sub>1</sub> h6</b>	28		38		48	
<b>D<sub>2</sub> h6</b>	35 - 40		40 - 50		50 - 60	
<b>E</b>	142		180		180	
<b>E<sub>1</sub></b>	165 (215) [265]		215 (265) [300]		215 (265) [300]	
<b>F</b>	13.5		18		18	
<b>F<sub>1</sub></b>	11 (13.5) [17]		13.5 (17.5) [17.5]		13.5 (17.5) [17.5]	
<b>G g6</b>	95		130		130	
<b>G<sub>1</sub> h7</b>	130 (180) [230]		180 (230) [250]		180 (230) [250]	
<b>H</b>	130		140		180	
<b>I</b>	13.5		0		0	
<b>L<sub>1</sub></b>	60		80		100	
<b>L<sub>2</sub></b>	70 (80)		80 (100)		100 (120)	
<b>M<sub>1</sub></b>	31		41		51.5	
<b>M<sub>2</sub></b>	38 - 43		43 - 53.5		53.5 - 64	
<b>N<sub>1</sub></b>	8		10		14	
<b>N<sub>2</sub></b>	10 - 12		12 - 14		14 - 18	
<b>P</b>	145		190		190	
<b>P<sub>1</sub></b>	200 (250) [300]		250 (300) [350]		250 (300) [350]	
<b>Q</b>	265	305	353 [367]		410 [424]	
<b>R</b>	130		165		165	
<b>R<sub>1</sub></b>	165 (215) [265]		215 (265) [300]		215 (265) [300]	
<b>S</b>	30		35 [49]		40 (54)	
<b>S<sub>1</sub></b>	40	80	82		79	
<b>U<sub>1</sub></b>	4 (4) [4]		4 (4) [4]		4 (4) [4]	
<b>V</b>	M8x18 (n° 8)		M10x25 (n° 8)		M10x25 (n° 8)	
<b>V<sub>1</sub></b>	M10x22		M12x28		M16x36	
<b>V<sub>2</sub></b>	M10x22 - M12x28		M12x28 - M16x36		M16x36 - M20x42	
<b>Z</b>	15		18		18	
<b>kg</b>	20	21.5	49	52	62	70

# RS-RT

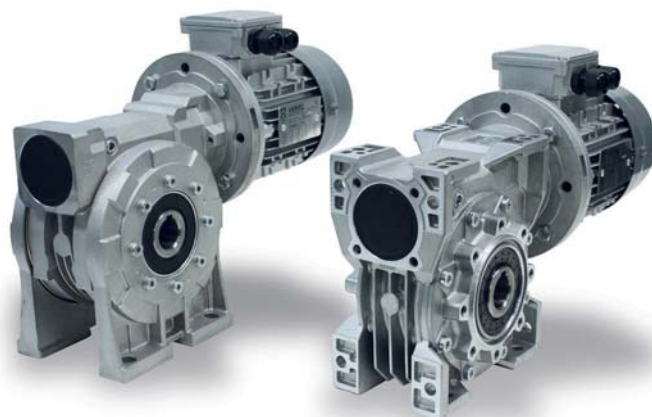
**RIDUTTORI A VITE SENZA FINE  
WORM GEARBOXES  
SCHNECKENGETRIEBE**



# RS-RT Riduttori - Gearboxes - Getriebe

## Dati tecnici - Technical data - Technische Daten

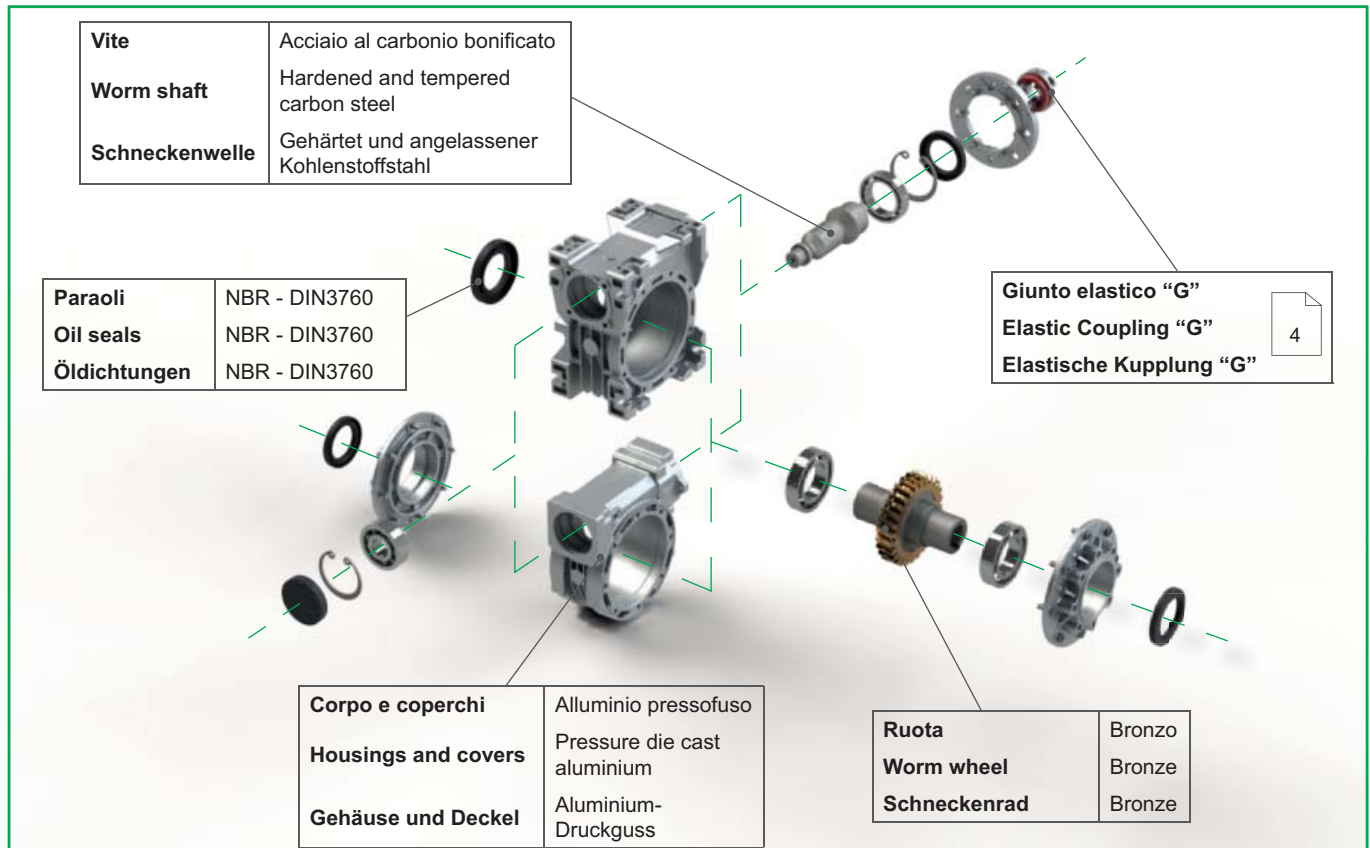

## Designazione - Designation - Bezeichnungen

<b>F</b>	<b>RS-G</b>	<b>..</b>	<b>/ 40</b>	<b>PC</b>	<b>28</b>	<b>IEC71</b>	<b>B14</b>	
M	RS-G	63	28	28	S	5	56	B5
F	RA	71	40	40	I	..	63	B14
S	RS/RS-G	80	50	50	D	..	71	
..	RT-G	100	60	60	PC	..	80	
	TA		70	70	FL	10000	90	
	RT/RT-G			85	B3		100	
				110	F		112	
				130			132	
				150			160	

Forma motore elettrico - Motor size - Motorbauform

Grandezza IEC motore elettrico - IEC motor size - IEC Motorbaugröße

Rapporto di riduzione - Reduction ratio - Getriebeübersetzung

Forma costruttiva riduttore - Gearbox form - Bauform des Getriebes

Grandezza 2° riduttore - 2nd worm gearbox size - Getriebegröße

Grandezza 1° riduttore - 1st worm gearbox size - Baugröße der 1. Getriebestufe

Grandezza precoppia - Helical stage size - Baugröße der Stirnradvorstufe

Tipo di riduttore - Gearbox type - Getriebetyp

M = Motoriduttore - Geared Motor - Getriebemotor  
 F = Riduttore con flangia di entrata - Gearbox with input flange - Getriebe mit Eingangsflansch  
 S = Riduttore senza flangia di entrata - Gearbox without input flange - Getriebe ohne Eingangsflansch  
 .. = Riduttore con albero di entrata sporgente - Gearbox with input free shaft - Getriebe mit freie Eingangswelle

## Getriebe - Gearboxes - Riduttori RS-RT

$n_1 = 1400 \text{ rpm}$

Technische Daten - Technical data - Dati tecnici

$P_1$ [kW]	Tipo riduttore Gearbox type Getriebe Typ	$i_n$	$n_2$ [rpm]	$M_2$ [Nm]
0.06	RS-RT 28	7	200	2.4
	RS-RT 28	10	140	3.3
	RS-RT 28	15	93	4.7
	RS-RT 28	20	70	6.1
	RS-RT 28	28	50	7.6
	RS-RT 28	40	35	10
	RS-RT 28	49	29	11
	RS-RT 28	56	25	12
	RS-RT 28	70	20	13
	RS-RT 40	80	18	16
	RS-RT 40	100	14	19
0.09	RS-RT 28	7	200	3.6
	RS-RT 28	10	140	5.0
	RS-RT 28	15	93	7.1
	RS-RT 28	20	70	9.1
	RS-RT 28	28	50	11
	RS-RT 28	40	35	15
	RS-RT 28	49	29	17
	RS-RT 40	56	25	20
	RS-RT 40	70	20	22
	RS-RT 40	80	18	25
	RS-RT 40	100	14	28
0.12	RS-RT 28	7	200	4.8
	RS-RT 28	10	140	6.6
	RS-RT 28	15	93	9.5
	RS-RT 28	20	70	12
	RS-RT 28	28	50	15
	RS-RT 40	40	35	20
	RS-RT 40	49	29	23
	RS-RT 40	56	25	26
	RS-RT 40	70	20	30
	RS-RT 40	80	18	33
	RS-RT 50	100	14	38
0.18	RS-RT 28	7	200	7.2
	RS-RT 28	10	140	9.9
	RS-RT 28	15	93	14
	RS-RT 40	20	70	18
	RS-RT 40	28	50	23
	RS-RT 40	40	35	30
	RS-RT 40	49	29	35
	RS-RT 40	56	25	39
	RS-RT 50	70	20	46
	RS-RT 50	80	18	51
	RS-RT 50	100	14	43

$P_1$ [kW]	Tipo riduttore Gearbox type Getriebe Typ	$i_n$	$n_2$ [rpm]	$M_2$ [Nm]
0.25	RS-RT 40	5	280	7.5
	RS-RT 40	7	200	10
	RS-RT 40	10	140	14
	RS-RT 40	15	93	20
	RS-RT 40	20	70	26
	RS-RT 40	28	50	32
	RS-RT 40	40	35	42
	RS-RT 50	49	29	52
	RS-RT 50	56	25	57
	RS-RT 50	70	20	63
	RS-RT 60	80	18	72
RS-RT 60	100	14	88	
0.37	RS-RT 40	5	280	11
	RS-RT 40	7	200	15
	RS-RT 40	10	140	21
	RS-RT 40	15	93	30
	RS-RT 40	20	70	38
	RS-RT 40	28	50	48
	RS-RT 50	40	35	65
	RS-RT 50	49	29	77
	RS-RT 60	56	25	85
	RS-RT 60	70	20	97
	RS-RT 60	80	18	107
RS-RT 60	100	14	130	
0.55	RS-RT 40	5	280	16
	RS-RT 50	7	200	23
	RS-RT 50	10	140	32
	RS-RT 50	15	93	44
	RS-RT 50	20	70	57
	RS-RT 50	28	50	75
	RS-RT 60	40	35	99
	RS-RT 60	49	29	114
	RS-RT 60	56	25	126
	RS-RT 70	70	20	155
	RS-RT 70	80	18	168
RS-RT 85	100	14	210	
0.75	RS-RT 50	5	280	23
	RS-RT 50	7	200	31
	RS-RT 50	10	140	43
	RS-RT 50	15	93	60
	RS-RT 60	20	70	79
	RS-RT 60	28	50	102
	RS-RT 60	40	35	135
	RS-RT 60	49	29	168
	RS-RT 70	70	20	210
	RS-RT 70	80	18	230
	RS-RT 70	100	14	280

## RS-RT Riduttori - Gearboxes - Getriebe

### Dati tecnici - Technical data - Technische Daten

 $n_1 = 1400 \text{ rpm}$ 

$P_1$ [kW]	Tipo riduttore Gearbox type Getriebe Typ	$i_n$	$n_2$ [rpm]	$M_2$ [Nm]
<b>0.75</b>	RS-RT 70	56	25	183
	RS-RT 85	70	20	226
	RS-RT 85	80	18	246
<b>1.1</b>	RS-RT 60	5	280	34
	RS-RT 60	7	200	45
	RS-RT 60	10	140	63
	RS-RT 60	15	93	91
	RS-RT 70	20	70	116
	RS-RT 70	28	50	158
	RS-RT 70	40	35	213
	RS-RT 85	49	29	246
	RS-RT 85	56	25	286
	RS-RT 110	70	20	352
	RS-RT 110	80	18	396
	RS-RT 110	100	14	458
	<b>1.5</b>	RS-RT 60	5	280
RS-RT 60		7	200	62
RS-RT 60		10	140	86
RS-RT 60		15	93	124
RS-RT 70		20	70	166
RS-RT 70		28	50	215
RS-RT 85		40	35	295
RS-RT 85		49	29	336
RS-RT 110		49	29	356
RS-RT 110		56	25	401
RS-RT 110		70	20	480
RS-RT 110		80	18	540
RS-RT 110		100	14	624
<b>2.2</b>	RS-RT 70	5	280	92
	RS-RT 70	7	200	92
	RS-RT 70	10	140	129
	RS-RT 70	15	93	187
	RS-RT 85	20	70	246
	RS-RT 85	28	50	319
	RS-RT 110	40	35	438
	RS-RT 110	49	29	522
	RS-RT 110	56	25	588
	RS-RT 110	70	20	704
	RS 130	80	18	756
	RS 150	100	14	945
	<b>3.0</b>	RS-RT 70	5	280
RS-RT 70		7	200	126
RS-RT 70		10	140	176
RS-RT 85		15	93	255

$P_1$ [kW]	Tipo riduttore Gearbox type Getriebe Typ	$i_n$	$n_2$ [rpm]	$M_2$ [Nm]
<b>3.0</b>	RS-RT 85	20	70	336
	RS-RT 110	28	50	435
	RS-RT 110	40	35	598
	RS-RT 110	49	29	712
	RS 130	49	29	722
	RS 130	56	25	814
	RS 150	70	20	974
	RS 150	80	18	1064
	RS 150	100	14	1289
<b>4.0</b>	RS-RT 85	5	280	122
	RS-RT 85	7	200	168
	RS-RT 85	10	140	235
	RS-RT 110	15	93	344
	RS-RT 110	20	70	453
	RS-RT 110	28	50	581
	RS 130	40	35	829
	RS 130	49	29	963
	RS 150	56	25	1085
<b>5.5</b>	RS-RT 110	56	25	1115
	RS 150	70	20	1299
	RS-RT 110	7	200	231
	RS-RT 110	10	140	326
	RS-RT 110	15	93	473
	RS-RT 110	20	70	623
	RS 130	28	50	809
	RS 130	40	35	1141
	RS 150	49	29	1342
<b>7.5</b>	RS 150	56	25	1534
	RS-RT 110	7	200	315
	RS-RT 110	10	140	445
	RS-RT 110	15	93	645
	RS 130	15	93	652
	RS 130	20	70	860
	RS 130	28	50	1103
	RS 150	40	35	1576
	<b>11.0</b>	RS 150	7	200
RS 150		10	140	660
RS 150		15	93	968
RS 150		20	70	1261
<b>15.0</b>		RS 150	7	200
	RS 150	10	140	900
	RS 150	15	93	1320



# Getriebe - Gearboxes - Riduttori RS-RT

## Abmessungen - Dimensions - Dimensioni

**PC**

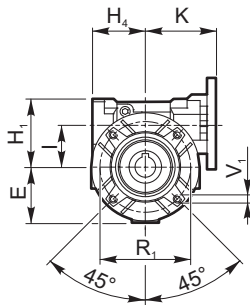

**S (I - D)**

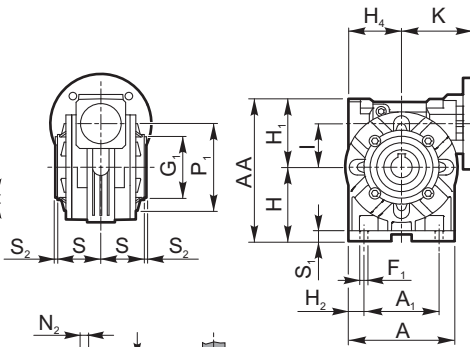

**FL**

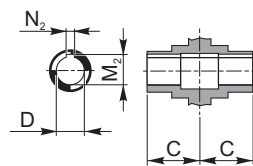
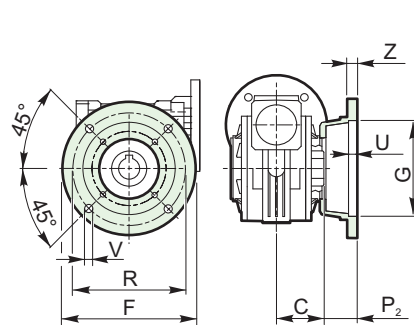

**RS**

	RS28	RS40	RS50	RS60	RS70	RS85	RS110	RS130	RS150
<b>A</b>	70	100	120	138	158	193	250	286	336
<b>A<sub>1</sub></b>	52	70	85	95	120	140	200	235	260
<b>AA</b>	99	138	163	192	221	252	333	400	454
<b>B</b>	78	102	119	136	140	168	200	230	250
<b>B</b>	66	84	99	111	116	140	162	190	210
<b>C</b>	30	41	49	60	60	61	77.5	90	105
<b>D H7</b>	14	19 - 18	24 - 25	25	28 - 30	32 - 35	42	48	55
<b>E</b>	34	50	61	70	80	98	125	143	168
<b>F</b>	70	140	160	180	200	200	250	300	350
<b>F<sub>1</sub></b>	5.5	7	9	11	11	13	14	15	19
<b>G H8</b>	40	95	110	115	130	130	180	230	250
<b>G<sub>1</sub> H8</b>	42	60	70	70	80	110	130	180	180
<b>H</b>	52	71	85	100	115	135	172	200	230
<b>H<sub>1</sub></b>	47	67	78	92	106	117	161	200	224
<b>H<sub>2</sub></b>	9	15	17.5	21.5	19	26.5	25	25.5	38
<b>H<sub>4</sub></b>	40	50	60	72	86	103	139	159	183
<b>I</b>	28	40	50	60	70	85	110	130	150
<b>K</b>	57.5	70.5	83 - 88*	93 - 94*	117 - 118*	134 - 137*	151 - 153*	165 - 166*	191 - 211*
<b>M<sub>2</sub></b>	16.3	21.8 - 20.8	27.3 - 28.3	28.3	31.3 - 33.3	35.3 - 38.3	45.3	51.8	59.3
<b>N<sub>2</sub></b>	5	6 - 6	8 - 8	8	8 - 8	10 - 10	12	14	16
<b>P</b>	49	82	91.5	116	111	100	150	150	160
<b>P<sub>1</sub></b>	67	94	100	102	118	150	200	234	250
<b>P<sub>2</sub></b>	19	41	42.5	56	51	39	72.5	60	55
<b>R</b>	56	115	130	150	165	165	215	265	300
<b>R<sub>1</sub></b>	56	83	85	85	100	130	165	215	215
<b>S</b>	32	38	49	57.5	57	56.5	74.5	87	102
<b>S<sub>1</sub></b>	6	9	12	12	14	15	17	19	20
<b>S<sub>2</sub></b>	3	2	2.5	2.5	3	3	2.5	5	5
<b>U</b>	4	6	10	10	12	6	5	5	6
<b>V</b>	6.5 (n°4)	9 (n°4)	9 (n°4)	11 (n°4)	13 (n°4)	13 (n°4)	15 (n°8)	15 (n°8)	19 (n°8)
<b>V<sub>1</sub></b>	M6x6 (n°4)	M6x9 (n°4)	M8x12 (n°4)	M8x15 (n°8)	M8x18 (n°8)	M10x20 (n°8)	M12x21 (n°8)	M12x24 (n°8)	M14x30 (n°8)
<b>Z</b>	6	10	10	11	14	14	16	18	20
<b>kg</b>	1.1	2.5	3.8	6.5	9	13.5	39	50	80

\* - IEC71-B14 (RS50 - RS60) - IEC80-B14 (RS70) - IEC90-B14 (RS85) - IEC100/112-B14 (RS110 - RS130 - RS150)

# RS-RT Riduttori - Gearboxes - Getriebe

## Dimensioni - Dimensions - Abmessungen

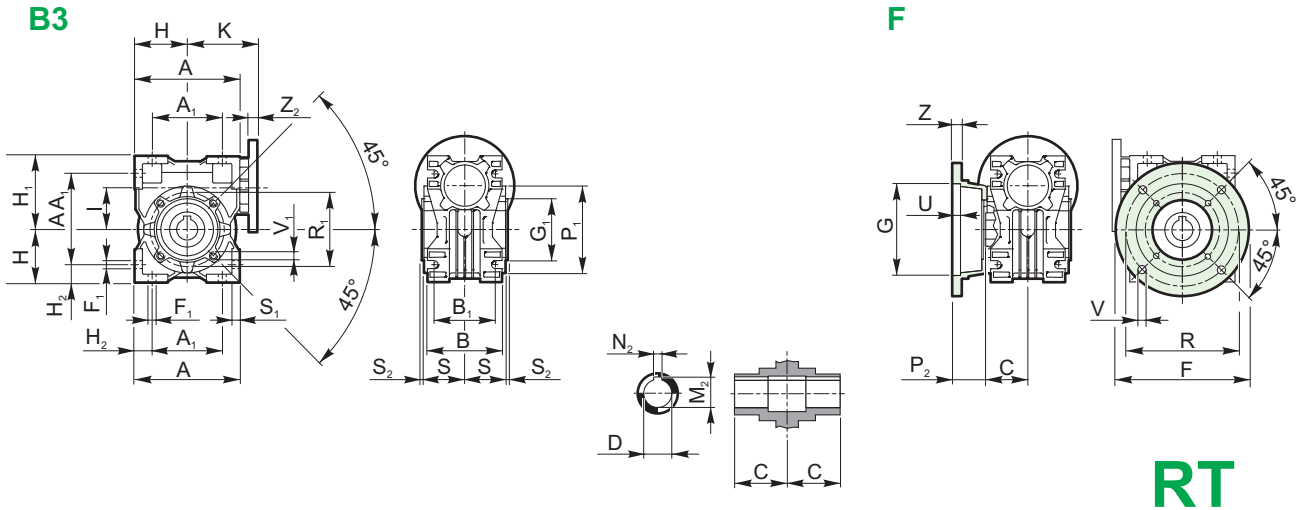

	RT28	RT40	RT50	RT60	RT70	RT85	RT110
<b>A</b>	80	100	120	144	172	206	255
<b>A<sub>1</sub></b>	54	70	80	100	120	140	170
<b>AA</b>	97	121.5	144	174	205	238	295
<b>AA<sub>1</sub></b>	71	91.5	104	130	153	172	210
<b>B</b>	53	71	85	100	112	130	144
<b>B<sub>1</sub></b>	44	60	70	85	90	100	115
<b>C</b>	30	41	49	60	60	61	77.5
<b>D H7</b>	14	19 - 18	24 - 25	25	28 - 30	32 - 35	42
<b>F</b>	80	110	125	180	200	210	270
<b>F<sub>1</sub></b>	7	7	9	9	11	13	15
<b>G H8</b>	50	60	70	115	130	152	170
<b>G<sub>1</sub> H8</b>	55	60	70	80	95	110	130
<b>H</b>	40	50	60	72	86	103	127.5
<b>H<sub>1</sub></b>	57	71.5	84	102	119	135	167.5
<b>H<sub>2</sub></b>	13	15	20	22	26	33	42.5
<b>I</b>	28	40	50	60	70	85	110
<b>K</b>	57.5	70.5	83 - 88*	93 - 94*	117 - 118*	134 - 137*	151 - 153*
<b>M<sub>2</sub></b>	16.3	21.8 - 20.8	27.3 - 28.3	28.3	31.3 - 33.3	35.3 - 38.3	45.3
<b>N<sub>2</sub></b>	5	6 - 6	8 - 8	8	8 - 8	10 - 10	12
<b>P</b>	53	69	93	86	111	111	131
<b>P<sub>1</sub></b>	75	86	100	110	130	160	200
<b>P<sub>2</sub></b>	23	28	44	25	51	50	53.5
<b>R</b>	68	87	90	150.5	165	175	230
<b>R<sub>1</sub></b>	65	75	85	95	115	130	165
<b>S</b>	27.5	38.5	46.5	57	57	67	74
<b>S<sub>1</sub></b>	6	7	8	10	11	14	13
<b>S<sub>2</sub></b>	2.5	2.5	3	3	3	3	3.5
<b>U</b>	10	4	5	6.5	12	6	5
<b>V</b>	7 (n° 4)	9 (n° 4)	11 (n° 4)	11 (n° 4)	13 (n° 4)	13 (n° 4)	14 (n° 8)
<b>V<sub>1</sub></b>	M6x10 (n° 4)	M6x8.5 (n° 4)	M8x10 (n° 4)	M8x20 (n° 8)	M8x16 (n° 8)	M10x18 (n° 8)	M10x21 (n° 8)
<b>Z</b>	7	6	10	10	14	16	18
<b>Z<sub>2</sub></b>	13	13	13	14 - 15	15.5 - 17.5	15.5 - 18.5	18 - 20
<b>kg</b>	1.1	2.5	3.8	6.5	9	13.5	39

\* - IEC71-B14 (RT50 - RT60) - IEC80-B14 (RT7) - IEC90-B14 (RT85) - IEC100/112-B14 (RT110)

ARGENTINA  
AUSTRALIA  
AUSTRIA  
BELARUS  
BELGIUM  
BRAZIL  
BULGARIA  
CANADA  
CHILE  
CHINA  
COLOMBIA  
COSTA RICA  
CROATIA  
CYPRUS  
CZECH REPUBLIC  
DENMARK  
ECUADOR  
EGYPT  
ESTONIA  
FINLAND  
FRANCE  
GERMANY  
GREECE  
HOLLAND  
HONG KONG  
HUNGARY  
ICELAND  
**INDIA • Branch**  
INDONESIA  
IRAN  
IRELAND  
ISRAEL  
**ITALY • Headquarters**  
KENYA  
KOREA (SOUTH)  
LEBANON  
LIBYA  
LITHUANIA  
MALAYSIA  
MAURITIUS  
MEXICO  
MOROCCO  
NEW ZEALAND  
NORWAY  
PAKISTAN  
PARAGUAY  
PERU  
POLAND  
PORTUGAL  
ROMANIA  
RUSSIA  
SAUDI ARABIA  
SERBIA  
SINGAPORE  
SLOVAKIA  
SLOVENIA  
SOUTH AFRICA  
SPAIN  
SWEDEN  
SWITZERLAND  
TAIWAN  
THAILAND  
TUNISIA  
TURKEY  
UKRAINE  
UNITED ARAB EMIRATES  
UNITED KINGDOM  
URUGUAY  
**USA • Branch**  
VIETNAM



India Branch:

**MGM-VARVEL** Power Transmission Pvt Ltd  
Warehouse N. G3 and G4 ▪ Ground Floor  
Indus Valley's Logistic Park ▪ Unit 3  
Mel Ayanambakkam ▪ Vellala Street  
Chennai - 600 095 ▪ Tamil Nadu, INDIA  
info@mgmvarvelindia.com  
www.mgmvarvelindia.com

USA Branch:

**VARVEL USA** LLC  
2815 Colonnades Court  
Peachtree Corners, GA 30071 ▪ USA  
☎ 770-217-4567  
☎ 770-255-1978  
info@varvelusa.com  
www.varvelusa.com



# VARVEL®

MOTION CONTROL SINCE 1955

technology made in Italy



**VARVEL** SpA

Via 2 Agosto 1980, 9 ▪ Loc. Crespellano  
40053 Valsamoggia (BO) ▪ Italy

☎ +39 051 6721811

☎ +39 051 6721825

varvel@varvel.com

www.varvel.com